



**EVALUATION REPORT**

**FLORIDA BUILDING CODE, 8<sup>TH</sup> EDITION (2023)**

**Manufacturer:** SHEFFIELD METALS INTERNATIONAL  
 5467 Evergreen Parkway  
 Sheffield Village, OH 44054  
 (800) 283-5262  
[www.sheffieldmetals.com](http://www.sheffieldmetals.com)

*Issued December 17, 2023*

**Quality Assurance:** Keystone Certifications ,Inc. (QUA1824)

**SCOPE**

**Category:** Panel Walls  
**Subcategory:** Siding  
**Code Edition:** Florida Building Code, 8<sup>th</sup> Edition (2023)  
**Code Sections:** 1404.5  
**Properties:** Wind Resistance

**REFERENCES**

<u>Entity</u>	<u>Report No.</u>	<u>Standard</u>	<u>Year</u>
Farabaugh Engineering and Testing, Inc. (TST1654)	T243-23	ASTM E 330	2014
Intertek - West Palm Beach (TST1527)	C7678.01-450-44	ASTM E 1592	2005(2017)
PRI Construction Materials Technologies (TST5878)	SHMI-006-02-01A	ASTM E 330	2014
PRI Construction Materials Technologies (TST5878)	SHMI-006-02-01B	ASTM E 330	2014

**PRODUCT DESCRIPTION**

**SMI 1.0 FWP**

**Profile:** 1 in. ribs; 12 in. coverage  
**Description:** Flush, interlocking wall panel  
**Material:** Min. 24 ga. ASTM A792 AZ50 SS Grade 50 steel;  
 Shall conform with FBC Section 1507.4.3

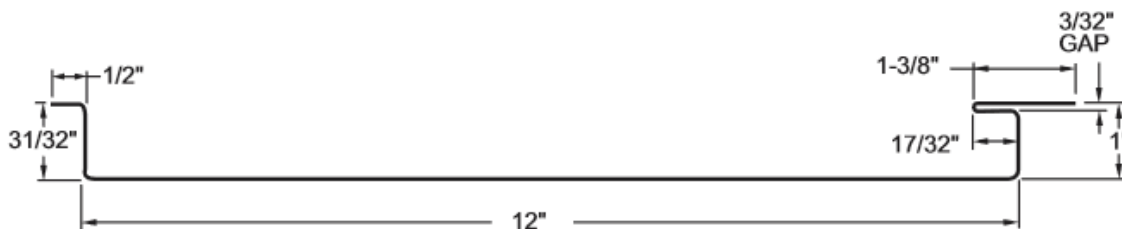

**SMI WAV-16-4C**

**Profile:** 7/8 in. ribs; 16 in. coverage  
**Description:** Corrugated wall panel  
**Material:** Min. 24ga. ASTM A792 SS Grade 50 steel;  
 Shall conform with FBC Section 1507.4.3



**SMI WAV-16-4F**

**Profile:** 7/8 in. ribs; 16 in. coverage  
**Description:** Corrugated, interlocking wall panel  
**Material:** Min. 24ga. ASTM A792 SS Grade 50 steel;  
 Shall conform with FBC Section 1507.4.3

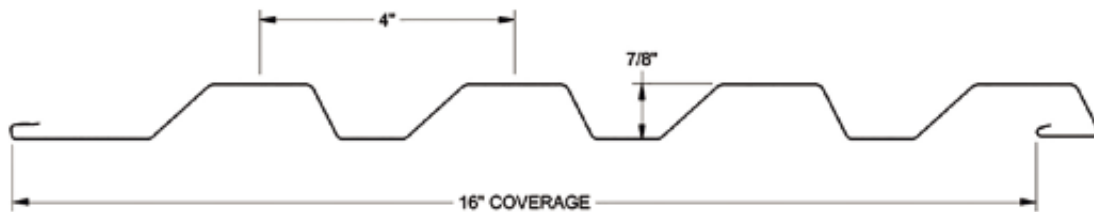

**SMI Board & Batten**

**Profile:** 3/4 in. ribs; 12 in. coverage  
**Description:** Interlocking wall panel  
**Material:** Min. 24 ga. ASTM A792 AZ50 SS Grade 50 steel;  
 Shall conform with FBC Section 1507.4.3



**APPROVED ASSEMBLIES**

<b>SMI 1.0 FWP-1</b>	
Steel Girts:	Min. 16 ga. steel spaced a maximum 48-inch o.c.
Attachment:	The female interlock leg of the panel shall be attached to each girt using one (1) #12 x min. 1-inch self-drilling pancake head screw. The male interlock shall be installed by sliding into the female interlock and stitching the seams using a single row of #12 x min. 1-inch self-drilling pancake head screws starting 3 1/2-inches from the end and continuing 24-inches o.c. thereafter. Fasteners shall penetrate through the steel girts a min. 3/4-inch. All fasteners shall be corrosion resistant in accordance with section 1507.4.4.
Maximum Design Pressures:	<b>-42.5 psf</b> <i>Based on three or more equal spans.</i>

<b>SMI 1.0 FWP-2</b>	
Steel Girts:	Min. 16 ga. spaced a maximum 12-inch o.c.
Attachment:	The female interlock leg of the panel shall be attached to each girt using one (1) #12 x min. 1-inch self-drilling pancake head screw. The male interlock shall be installed by sliding into the female interlock and stitching the seams using a single row of #12 x min. 1-inch self-drilling pancake head screws starting 3 1/2-inches from the end and continuing 24-inches o.c. thereafter. Fasteners shall penetrate through the steel girts a min. 3/4-inch. All fasteners shall be corrosion resistant in accordance with section 1507.4.4.
Maximum Design Pressures:	<b>-65 psf</b> <i>Based on three or more equal spans.</i>

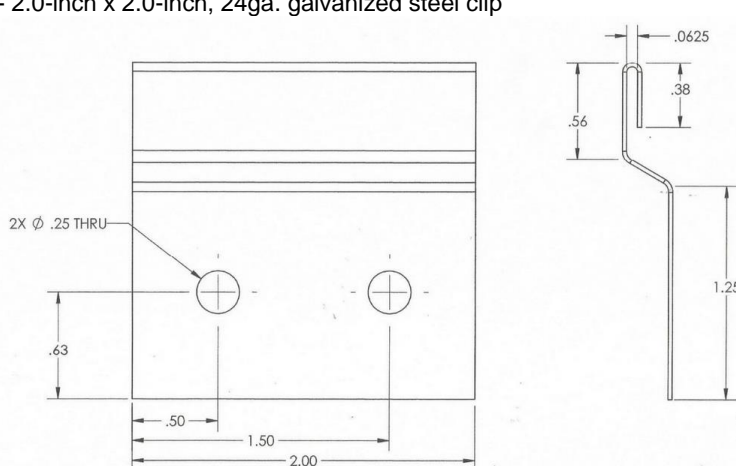
<b>SMI WAV-16-4C-1</b>	
Steel Girts:	Min. 18 ga. steel with minimum 2-inch wide bearing surface spaced a maximum 48-inch o.c. Girts shall be designed by others in accordance with FBC requirements.
Attachment:	<p>WAV Clips shall be fastened to each girt with two (2) #10-16 x min. 1-inch screws per clip and hooked to the return leg of the panel. Fasteners shall penetrate through the steel girts a min. 3/4-inch. All fasteners shall be corrosion resistant in accordance with section 1507.4.4.</p> <p>WAV Clip - 2.0-inch x 2.0-inch, 24ga. galvanized steel clip</p> 
Maximum Design Pressures:	<b>+82.5 psf</b> <b>-30 psf</b> <i>Based on three or more equal spans.</i>

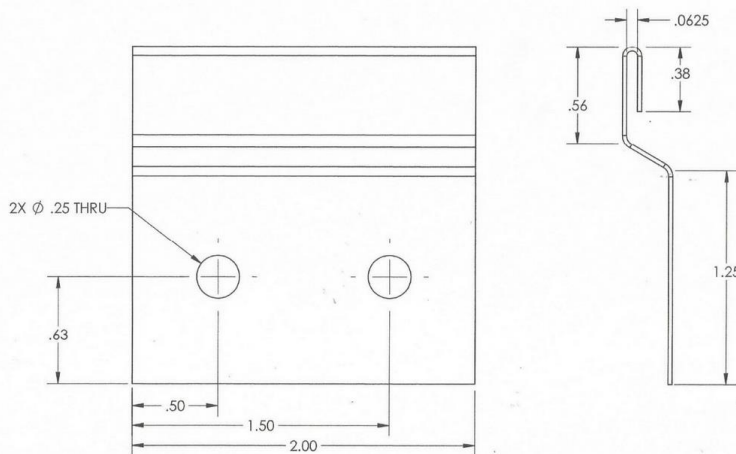
<b>SMI WAV-16-4C-2</b>	
Steel Girts:	Min. 18 ga. steel with minimum 2-inch wide bearing surface spaced a maximum 12-inch o.c. Girts shall be designed by others in accordance with FBC requirements.
Attachment:	WAV Clips shall be fastened to each girt with two (2) #10-16 x min. 1-inch screws per clip and hooked to the return leg of the panel. Fasteners shall penetrate through the steel girts a min. 3/4-inch. All fasteners shall be corrosion resistant in accordance with section 1507.4.4.
	WAV Clip - 2.0-inch x 2.0-inch, 24ga. galvanized steel clip 
Maximum Design Pressures:	<b>+82.5 psf</b> <b>-37.5 psf</b> <i>Based on three or more equal spans.</i>

<b>SMI WAV-16-4F-1</b>	
Steel Girts:	Min. 18 ga. steel with minimum 2-inch wide bearing surface spaced a maximum 48-inch o.c. Girts shall be designed by others in accordance with FBC requirements.
Attachment:	#10-16 x min. 1-inch screws shall be secured through the panel into each girt, 1-inch from the return leg prior to adjoining panels. Fasteners shall penetrate through the steel girts a min. 3/4-inch. All fasteners shall be corrosion resistant in accordance with section 1507.4.4.
Maximum Design Pressures:	<b>+60 psf</b> <b>-45 psf</b> <i>Based on three or more equal spans.</i>

<b>SMI WAV-16-4F-2</b>	
Steel Girts:	Min. 18 ga. steel with minimum 2-inch wide bearing surface spaced a maximum 12-inch o.c. Girts shall be designed by others in accordance with FBC requirements.
Attachment:	#10-16 x min. 1-inch screws shall be secured through the panel into each girt, 1-inch from the return leg prior to adjoining panels. Fasteners shall penetrate through the steel girts a min. 3/4-inch. All fasteners shall be corrosion resistant in accordance with section 1507.4.4.
Maximum Design Pressures:	<b>+110 psf</b> <b>-67.5 psf</b> <i>Based on three or more equal spans.</i>



<b>SMI Board &amp; Batten-1</b>	
Wall Substrate:	Min. 15/32 in., 32/16 span rated, 4-ply, CDX plywood sheathing at max. 24 in. span. Shall be designed by others in accordance with FBC requirements.
Attachment:	#10-12 x min. 1-inch pancake head screws shall be secured 12 7/8-inch o.c. into every other slot along the length of the panel adjacent to the male interlock. The female interlock shall be installed by sliding over the male interlock. Fasteners shall penetrate through the sheathing a min. 3/8-inch. All fasteners shall be corrosion resistant in accordance with section 1507.4.4.
Maximum Design Pressures:	<b>+45 psf</b> <b>-41.6 psf</b> <i>Based on three or more spans.</i>

**LIMITATIONS**

---

1. This report is not for use in the HVHZ.
2. Fire classification is not within the scope of this evaluation.
3. The design wind loads shall be determined by others in accordance Section 1603.1.4 of the FBC.
4. Rational analysis shall be prepared by a qualified design professional in accordance with the FBC. Design analysis shall consider web crippling and fastener pullout/pullover in accordance with Section 2210 of the FBC.
5. Diaphragm and axial capacity are not within scope of this evaluation.
6. Installation of the evaluated products shall comply with this report, the FBC and the manufacturer's published application instructions. Where discrepancies exist between these sources, the more restrictive and FBC compliant installation detail shall prevail.
7. All products listed in this report shall be manufactured under a quality assurance program in compliance with Rule 61G20-3.

**COMPLIANCE STATEMENT**

---

The products evaluated herein by Zachary R. Priest, P.E. have demonstrated compliance with the Florida Building Code, 8<sup>th</sup> Edition (2023) as evidenced in the referenced documents submitted by the named manufacturer.

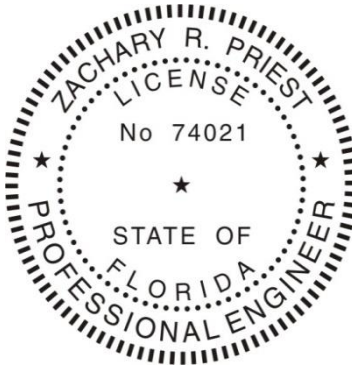

**This item has been digitally signed and sealed by Zachary R. Priest, PE, on 12/17/2023.**

**Printed copies of this document are not considered signed and sealed and the signature must be verified on any electronic copies.**

Zachary R. Priest, P.E.  
Florida Registration No. 74021  
Organization No. ANE9641

**CERTIFICATION OF INDEPENDENCE**

---

CREEK Technical Services, LLC does not have, nor will it acquire, a financial interest in any company manufacturing or distributing products under this evaluation.

CREEK Technical Services, LLC is not owned, operated, or controlled by any company manufacturing or distributing products under this evaluation.

Zachary R. Priest, P.E. does not have, nor will acquire, a financial interest in any company manufacturing or distributing products under this evaluation.

Zachary R. Priest, P.E. does not have, nor will acquire, a financial interest in any other entity involved in the approval process of the product.

**END OF REPORT**